

McKean County Conservation District Erosion & Sediment Control Guidelines For Small Projects

Use of this Guide

This guide is only for use in developing Erosion & Sediment (E&S) Control Plans for small projects that meet the following criteria:

- ⇒ Slopes do not exceed a 10 % grade
- ⇒ There are no surface waters in close proximity to the proposed project
- ⇒ Erosion control practices being used do not require calculations
- ⇒ Total area of disturbance is less than 1 Acre

This guide may also be used to develop E&S Control Plans when the landowner is submitting a Chapter 105 General Permit for acknowledgement. In addition, check with your municipality to determine if any local ordinance provisions or permit requirements apply to your project.

Please Note: This guide is not appropriate for every project! Your project must meet the criteria listed above in order to use this guide to develop your E&S Control Plan. For larger, more complex projects, a detailed *Erosion and Sedimentation Pollution Control Manual* is available through the Conservation District. Check your yellow pages for engineers or other consultants that can assist in developing E&S Control Plans. Contact the McKean County Conservation District if you are unsure of the suitability of this guide for your project. Telephone: 814-887-4002.

Erosion and Sedimentation is a Serious Pollution Problem

Soil sediment is the number one pollutant to Pennsylvania's water resources. Sediment reduces water quality, degrades aquatic habitats killing fish and other aquatic life, and increases the frequency and intensity of flooding events. Any activity that disturbs the surface of the land can cause erosion and sedimentation. Completing and properly implementing an E&S Control Plan for your earth disturbance project will help protect McKean County's soil and water resources as well as the County's economic sustainability and quality of life.

State and Federal Regulations Require E&S Control Plans

To address the problem of sediment pollution, the Commonwealth of Pennsylvania, Department of Environmental Protection (DEP), adopted Chapter 102, Erosion and Sediment Control Rules and Regulations. Chapter 102 requires persons proposing or conducting earth disturbance activities to develop, implement and maintain *Best Management Practices* to minimize the potential for accelerated erosion and sedimentation. A written E&S Control Plan is required for all earth disturbance activities with the potential for discharge to waters classified as "High Quality" or "Exceptional Value" waters. In addition, the E&S Plan must be available at the project site during all stages of the earth disturbance activity. The plan must be submitted to the Conservation District for review if required by the local municipality (or, in some cases, a Community Association) or requested by the Conservation District. Both landowners and contractors may be held responsible for any violation(s) of Chapter 102 regulations.

A Note about Streams, Floodways, Wetlands & Other Bodies of Water:

Any encroachment on any watercourse, floodway, or body of water without the appropriate federal and state permits is strictly prohibited by the Federal Clean Water Act, the Commonwealth of Pennsylvania's Dam Safety and Encroachments Act, The Clean Stream Law and Chapter 105 rules and regulations. In addition, some local municipalities have setbacks and other ordinances provisions related to water resources that may be applicable to certain land development activities. Plan ahead to avoid these areas or inquire about permits and other requirements well BEFORE beginning your project.

Putting Your Plan on Paper

What to Include in a Small Project E&S Control Plan:

1. **Existing topography** (physical features) of the site and immediate surrounding area.
2. **Types of soils** on the site – refers to the County Soil Survey, available at the Conservation District or online at www.soils.usda.gov/survey.
3. **A description of land use:** Describe past, present and proposed land uses and all proposed alterations to the site.
4. **Location of any surface water** (streams, ponds, wetlands, springs, etc.).
5. **A description of proposed E&S best management practices**, both temporary (such as hay bale barriers, silt fence, stone filters) and permanent (such as seeding and mulching, rock-lined channels, etc.).
6. **The sequence of earthmoving activities:** Outline the sequence in which the earthmoving will occur, remembering that the most effective method of controlling erosion is to disturb only those areas necessary to complete a project. E&S best management practices should be in place before the site is disturbed. Disturbed areas should be permanently stabilized immediately after earth-moving is completed or temporary stabilized if delays in completing a project are anticipated.
7. **A maintenance plan** for all of the E&S best management practices being used on site.

Getting Started

First things first! Implementing the following guidelines will minimize erosion and save money:

- **Avoid disturbing existing vegetation** – Vegetative cover is the most effective and economical protection against soil erosion. Whenever possible, protect existing vegetation during the construction process. Trees and shrubs should be marked and roped off to prevent damage by construction equipment. Filling and soil compaction around trees can result in permanent damage to trees and should be avoided.
- **Save topsoil** – Stockpile all topsoil from cuts and fills and redistribute uniformly after grading. This is key to properly revegetating and stabilizing a disturbed site.
- **Minimize the area and time of exposure**- Disturb the minimum area required to complete a project. Don't start a job then leave it unfinished to work elsewhere. Plan your project to keep areas of disturbance and length of time that disturbed soil is exposed to a minimum. Stabilize disturbed areas immediately as they are completed.
- **Work in the dry** – Plan work to avoid periods of bad weather. If your project involves work in or around watercourses, work only during periods of low flow. Flowing water should always be diverted around disturbed areas.
- **Avoid steep slopes** - Steep slopes generally require more E&S controls than in gently sloping sites. Avoid excessive cutting and filling and road grades in excess of 10%.
- **Plan to protect ditches, streams and other bodies of water** - Maintain existing vegetation along streams. Install temporary controls, such as silt fence, hay bales or rock filter berms to keep sediment from traveling to streams, wetlands and other surface water.
- **Plan to maintain erosion control measures** – Hay bales deteriorate, silt fence clog with sediment and seeded areas wash out. Schedule regular maintenance checks to ensure properly functioning erosion control measures. Upgrade control measures when they fail or if maintenance problems occur frequently.

Timing is Everything!

Sample Sequence of Earthmoving Activity

1. **Install a tire cleaning, stabilized rock construction entrance** to keep dirt from being tracked onto adjacent roadways (see details).
2. **Install temporary E&S best management practices** such as hay bale, silt fence, etc. (see details).
3. **Clear and rough grade site.**
4. **Stockpile topsoil.** Temporary protection (hay bales or silt fence) should be installed down slope (lower side) of the stockpile or the stockpile should be immediately stabilized with temporary seed (e.g., annual rye-grass) and mulched.
5. **Install and immediately stabilize any watercourse** (swales, ditches, etc.) with appropriate lining (e.g., seed, mulch, matting or netting, sod or stone).
6. **Construct structure(s).**
7. **Finish, grade, and permanently stabilize** (seed, mulch, sod, etc.) the site.
8. **Maintain temporary E&S best management practices until grass is established.** A minimum of 70% stabilization of disturbed area with perennial vegetative cover or other permanent non-vegetative cover must be achieved before temporary erosion controls are removed.
9. **Remove temporary E&S best management practices** if applicable.

The Grass is Always Greener...

Tips for Successful Re-establishment of Vegetation

- ✓ **Time of Seeding** – For best results, grass and legumes seeding should be done in the spring. Seed mixtures that are primarily grass are best for fall planting. However, through proper seed selection and site preparation and seeding methods, disturbed sites can be seeded at almost any time from spring to fall.
- ✓ **Surface Preparation** – Spread topsoil and prepare a smooth seed bed by rolling and/or raking.
- ✓ **Lime and Fertilizer** – Many disturbed sites are acidic and infertile – don't skip this step! A soil test determines the amounts of lime and fertilizer to apply. If soil test results are not available, apply at least 6 tons of agricultural grade limestone and 100 pounds of 10-20-20 fertilizer per acre and work both as deeply as possible into soil.
- ✓ **Choice of Seed Mixtures** – Choose a seed mixture that fits your particular site conditions. (Refer to *Some Suggested Temporary & Permanent Seeding Mixtures for Erosion Control* later in this publication.) Remember that “cheap” seed is generally not a bargain – it often has poor germination rates and may contain excessive amounts of weed seeds.
- ✓ **Seeding Methods** – Seeds applied with a drill should be planted at a controlled depth and the soil firmed around them to provide moisture for germination and growth. Surface broadcasting of seed is rarely successful without a layer of mulch applied at the necessary rates. Hydro seeding is another method of seeding where the seed, fertilizer and mulch are mixed with water and applied as a slurry. Some local landscapers or earthmoving contractors have equipment necessary for hydro seeding, generally used for revegetating larger disturbed areas.
- ✓ **Mulching** – All disturbed areas, regardless of seeding method, should be mulched to reduce erosion and aid seed germination. Hay and straw preferred mulches and should be applied to produce a layer $\frac{3}{4}$ to 1 inch deep. Generally, 3 tons of mulch per acre (approximately 3 bales per 1000 sq. ft.) is sufficient. Straw or hay should not be chopped or finally broken.
- ✓ **Erosion Control Matting** – Helps hold seed and mulch in place, is required on all slopes with a 3 to 1 (33%) or steeper slope.
- ✓ **Water** – Don't forget to thoroughly water seed areas during dry periods. For best results and to conserve water, water early in the morning or in the early evening, when sun and wind are at a minimum

Some Suggested Temporary and Permanent Seed Mixtures for Erosion Control

Site Description	Species	Pounds/Acre	Pounds/1000 sq. ft
<i>Permanent Seeding</i>			
Slopes & Banks (non-mowed) Well Drained/Sunny	Sunny Birdsfoot trefoil,	6	0.15 (3 oz.)
	plus tall fescue	30	0.7 (11 oz.)
	or		
	Flatpea,	10	0.25 (4 oz.)
	plus tall fescue	20	0.5 (8 oz.)
	or perennial ryegrass	20	0.5 (8 oz.)
or			
Switchgrass or big bluestem,	15	0.3 (5 oz.)	
plus birdsfoot trefoil	6	0.15 (3 oz.)	
Slopes & Banks (mowed) Variable Drainage/Shaded	Birdsfoot trefoil,	6	0.15 (3 oz.)
	plus tall fescue,	30	0.7 (11 oz.)
	plus redtop	3	0.1 (2 oz.)
	or		
	tall fescue,	60	1.4 (22 oz.)
	plus redtop	3	0.1 (2 oz.)
Slopes & Banks (mowed) Well Drained	Tall fescue,	60	1.4 (22 oz.)
	plus fine fescue,	35	0.8 (13 oz.)
	or Kentucky bluegrass,	25	0.6 (10 oz.)
	plus redtop	3	0.1 (2 oz.)
	or		
	Perennial ryegrass	15	0.3 (5 oz.)
	plus tall fescue	40	1.0 (16 oz.)
	plus fine fescue	10	0.25 (4 oz.)
<i>Temporary Seeding</i>			
	Annual ryegrass (spring or fall),	40	1.0 (16 oz.)
	or spring oats (spring),	96	2.2 (35 oz.)
	or winter wheat (fall),	180	4.1 (66 oz.)
	or winter rye (fall)	168	3.8 (62 oz.)

Sample Small Project Erosion and Sediment Control Plan Drawing

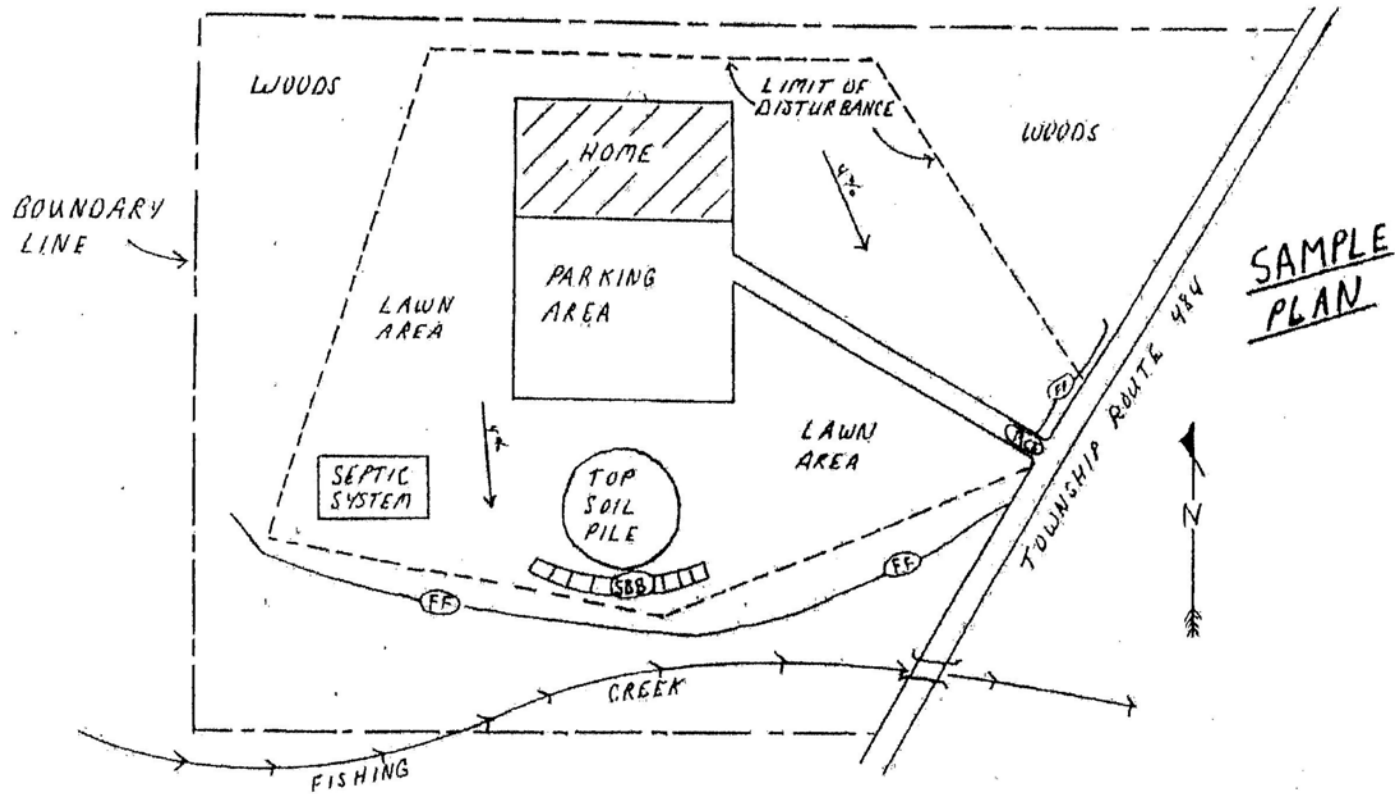

— LEGEND & SYMBOLS —

ROAD		CULVERT	
STREAM		STRAW BALE BARRIER	
BOUNDARY LINE		FILTER FABRIC FENCE	
SLOPE		ROCK FILTER BERM	
ROCK CONSTRUCTION		LIMIT OF DISTURBANCE	
ENTRANCE		DRAINAGE SWALE	

— GENERAL INFORMATION —

PROPERTY OWNER: John Doe
 PROJECT: Doe Home
 MUNICIPALITY: Doe Township
 DATE: 00-00-00
 APPROXIMATE SCALE: 1" = 50'

Small Project Erosion & Sediment Control Plan

Applicant: _____ Date: _____.

Address: _____.

City: _____ State: _____ Zip: _____.

Telephone: _____ Municipality: _____.

Contact person (if other than applicant): _____ Phone #: _____.

Location (Include copy of topographic map): _____.

Name of nearest receiving stream or body of water: _____.

Estimated dates for start-up and completion: Start: _____ End: _____.

Type of project (house, addition, store, etc.): _____.

Project acres (entire lot size): _____ Disturbed acres: _____.

Present site conditions (vegetative cover, existing disturbance, type of land use, etc.): _____.

_____.

Soil type (s) (Include Soil Map): _____.

NARRATIVE (Provide detailed description of proposed work)

SEQUENCE OF CONSTRUCTION (Label each step in numerical order - be specific)

TEMPORARY CONTROLS

Detail any temporary E&S best management practices that will be implemented. List each practice separately; explain why it is needed, and when it can safely be removed. Drawings and designs for any best management practices not illustrated in this guide should be attached and referenced in this section.

PERMANENT CONTROLS

Prior to completion of the project, state law requires that steps be taken to provide permanent stabilization. Re-establishment of vegetation, riprap, gravel or pavement, etc. is examples of permanent controls. Descriptions for re-vegetating should include the seeding mixture to be used, top soil applications, and lime and fertilizer instructions.

MAINTENANCE PROGRAM

All E&S best management practices require maintenance to function properly. Hay bale dikes deteriorate and clog with sediment. Newly seeded areas may fail to germinate or be washed out by heavy rain. Hay bale dikes and filter fabric fences should be cleaned when they reach half of their capacity. Describe all measures that will be implemented to ensure that E&S best management practices will continue to function properly and specify who will be responsible for maintenance activities.

*****IMPORTANT*****

- ✓ Keep a copy of this plan for your records. This plan must be on site at all times during earthmoving. **PROVIDE A COPY TO YOUR CONTRACTOR**, if applicable.
- ✓ **To ensure prompt review of your project, include all required information:** Topographic Map, Soil Map, completed Small Project E&S Control Plan, Small Project Control Plan Drawing and a completed E&S Control Plan Review Application. Do not mail entire guideline package.
- ✓ Mail to: **McKean County Conservation District, 17137 Route 6, Smethport, PA 16749**
- ✓ Please allow adequate time for review of your plan. Plan submissions are reviewed in the order in which they are received generally within 30 business days.
- ✓ Check with your municipality regarding any local ordinance provisions or permit requirements that may apply to your project.

SKETCH PLAN

To ensure the sketch plan is complete, include the following on the site plan in the immediate vicinity of the project.
(√ all that apply)

<input type="checkbox"/>	<input type="checkbox"/>	Stream Impacts with Dimensions Total Length _____ Total sq. ft. _____	<input type="checkbox"/>	<input type="checkbox"/>	Stream Name _____
<input type="checkbox"/>	<input type="checkbox"/>	Wetland Impacts Total _____ sq. ft.	<input type="checkbox"/>	<input type="checkbox"/>	Chapter 93 Stream Designation _____
<input type="checkbox"/>	<input type="checkbox"/>	Wetland Acreage Onsite _____	<input type="checkbox"/>	<input type="checkbox"/>	Location of Property Lines Relative to the Project
<input type="checkbox"/>	<input type="checkbox"/>	Stream Limits and Flow Direction	<input type="checkbox"/>	<input type="checkbox"/>	Existing Utilities
<input type="checkbox"/>	<input type="checkbox"/>	Floodway Limits (if known)	<input type="checkbox"/>	<input type="checkbox"/>	Proposed Utilities
<input type="checkbox"/>	<input type="checkbox"/>	Limits of Earth Disturbance Associated with this Activity	<input type="checkbox"/>	<input type="checkbox"/>	Existing Buildings, Roadways, Other Structures
			<input type="checkbox"/>	<input type="checkbox"/>	Proposed Buildings, Roadways, Other Structures
			<input type="checkbox"/>	<input type="checkbox"/>	Other Waters (i.e. pond, lakes)

|_____||
Scale 1" = _____ft.

CROSS SECTIONS AND PLAN VIEWS

Provide a cross section and plan view of the project showing the dimensions of the waterway opening, area of fill materials used, and other pertinent information necessary to accurately depict the scope of your project.

Best Management Practices

Straw Bale Barriers

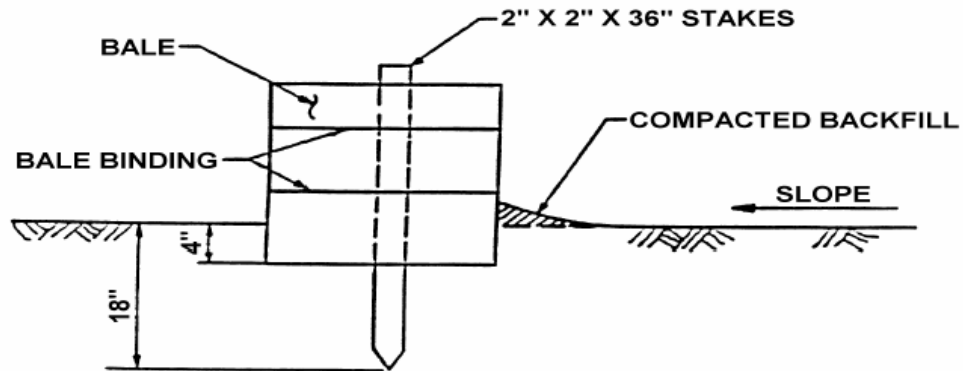

Straw Bale Barriers should not be used for more than 3 months.

Straw Bale Barriers shall be placed at existing level grade. Both ends of the barrier shall be extended at least 8 feet up slope at 45 degrees to the main barrier alignment.

Sediment shall be removed when accumulations reach 1/3 the above ground height of the barrier.

Any section of Straw Bale Barrier which has been undermined or topped shall be immediately replaced with a Rock Filter Outlet. See Standard Construction Detail #18.

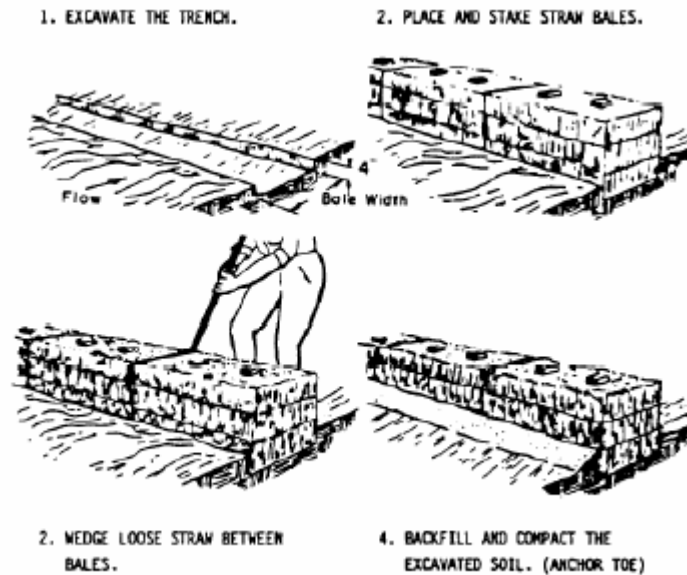

Standard Filter Fence (18" High)

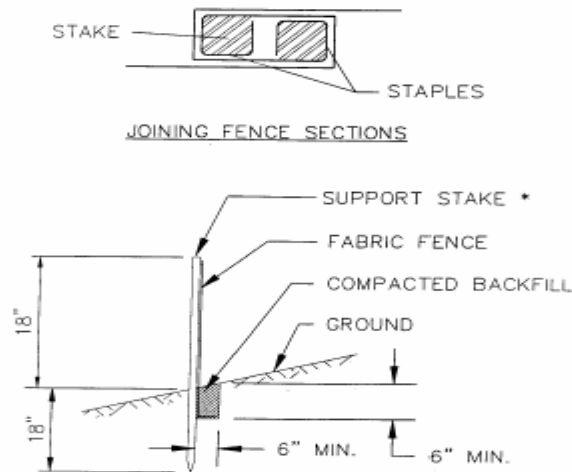

*Stakes spaced @ 8' maximum. Use 2"x 2" wood or equivalent steel stakes.

Filter Fabric Fence must be placed at level existing grade. Both ends of the barrier must be extended at least 8 feet up slope at 45 degrees to the main barrier alignment.

Sediment must be removed when accumulations reach 1/2 the above ground height of the fence.

Any section of Filter fabric fence which has been undermined or topped must be immediately replaced with a Rock Filter Outlet. See Standard Construction Detail # 18.

STANDARD CONSTRUCTION DETAIL # 20 Reinforced Filter Fabric Fence (30" High)

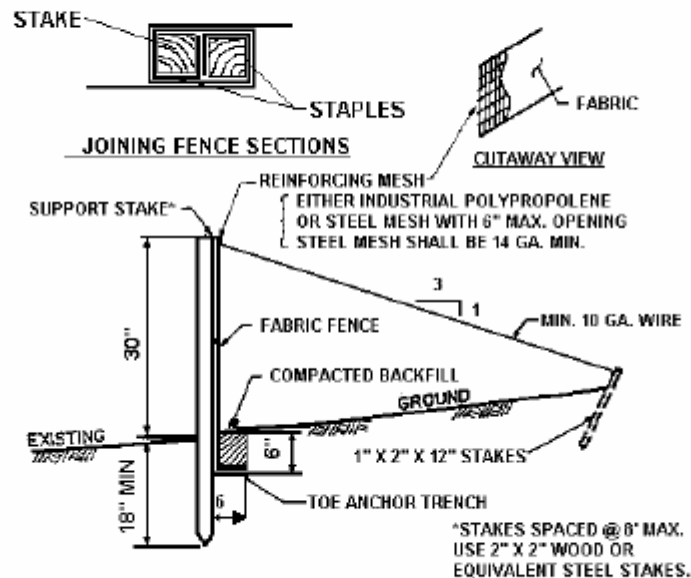

NOTE: SHOW ALL DETAILS AND CONSTRUCTION DIMENSIONS ON PLAN DRAWINGS.

Rock Construction Entrance

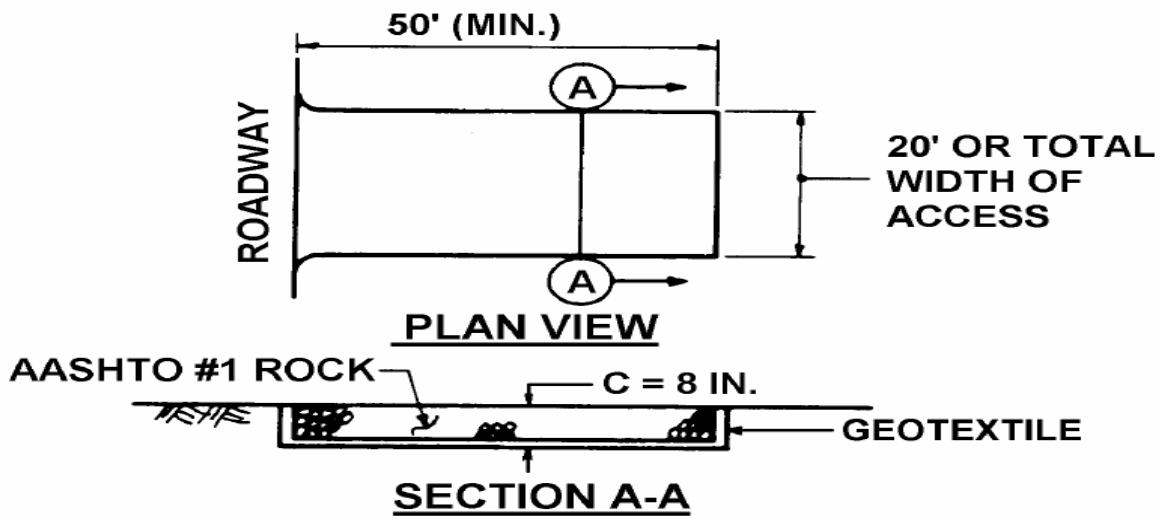

MAINTENANCE: Rock Construction Entrance thickness shall be constantly maintained to the specified dimensions by adding rock. A stockpile shall be maintained on site for this purpose. At the end of each construction day, all sediment deposited on paved roadways shall be removed and returned to the construction site.

STANDARD CONSTRUCTION DETAIL #18
Rock Filter Outlets

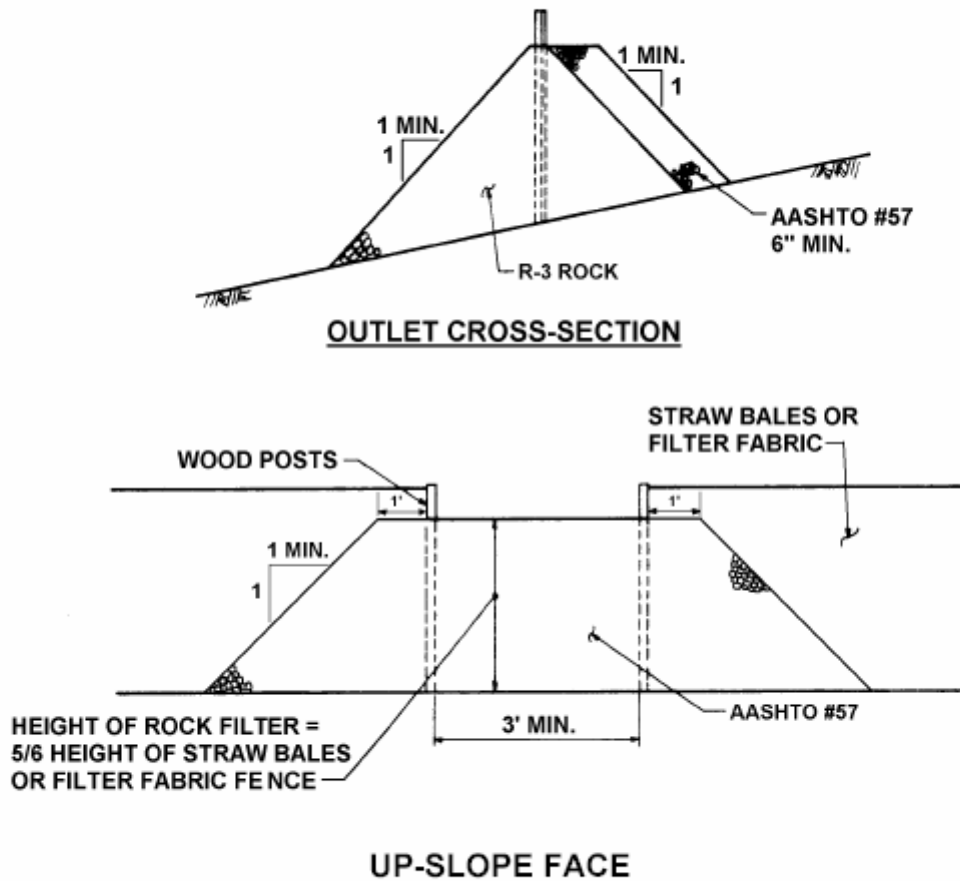

Sediment must be removed when accumulations reach 1/3 the height of the outlet.

For information or assistance contact:
McKean County Conservation District
17137 Route 6
Smethport, PA 16749
Phone: (814) 887-4001
Fax: (814) 887-3234
E-Mail: ceriedmiller@mckeancountypa.org

PROCEDURES

Applicants will submit one copy of the complete subdivision or site E&S plan and a copy of the erosion and sedimentation pollution control narrative, a completed application form (not required when application is made for an NPDES permit for Construction Activities at the same time), a location map (USGS Quad. map is recommended), and a check or money order payable to the “McKean County Conservation District”. No cash payments will be accepted.

The Conservation District review fee shall not be combined with any other required fees.

Submissions not containing the appropriate information will not be reviewed. The applicant will be informed of any additional information or fees needed for a review.

A \$20.00 charge plus any bank fees will be assessed for any check refused by the bank for insufficient funds, and the entire application package will be returned to the applicant.

Financial and other support for this project is provided by the Pennsylvania Association of Conservation Districts, Inc and the Pennsylvania Department of Environmental Protection’s Chesapeake Bay Program

